

## S611 Soft Starter

# Quick Start Installation Guide

Effective January 2012  
Supersedes June 2011

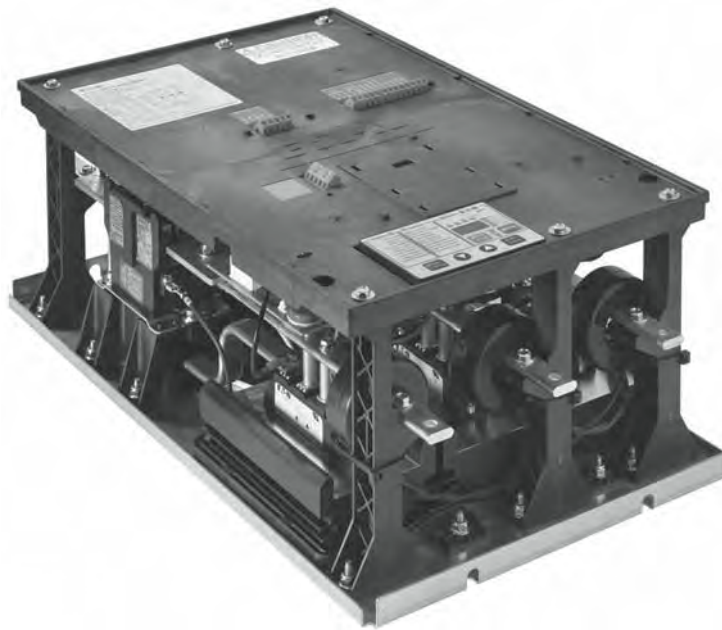



## **Disclaimer of Warranties and Limitation of Liability**

The information, recommendations, descriptions and safety notations in this document are based on Eaton Corporation's ("Eaton") experience and judgment and may not cover all contingencies. If further information is required, an Eaton sales office should be consulted. Sale of the product shown in this literature is subject to the terms and conditions outlined in appropriate Eaton selling policies or other contractual agreement between Eaton and the purchaser.

THERE ARE NO UNDERSTANDINGS, AGREEMENTS, WARRANTIES, EXPRESSED OR IMPLIED, INCLUDING WARRANTIES OF FITNESS FOR A PARTICULAR PURPOSE OR MERCHANTABILITY, OTHER THAN THOSE SPECIFICALLY SET OUT IN ANY EXISTING CONTRACT BETWEEN THE PARTIES. ANY SUCH CONTRACT STATES THE ENTIRE OBLIGATION OF EATON. THE CONTENTS OF THIS DOCUMENT SHALL NOT BECOME PART OF OR MODIFY ANY CONTRACT BETWEEN THE PARTIES.

In no event will Eaton be responsible to the purchaser or user in contract, in tort (including negligence), strict liability or otherwise for any special, indirect, incidental or consequential damage or loss whatsoever, including but not limited to damage or loss of use of equipment, plant or power system, cost of capital, loss of power, additional expenses in the use of existing power facilities, or claims against the purchaser or user by its customers resulting from the use of the information, recommendations and descriptions contained herein. The information contained in this manual is subject to change without notice.

Cover Photo: S611 Soft Starter

### Support Services

The goal of Eaton is to ensure your greatest possible satisfaction with the operation of our products. We are dedicated to providing fast, friendly, and accurate assistance. That is why we offer you so many ways to get the support you need. Whether it's by phone, fax, or e-mail, you can access Eaton's support information 24 hours a day, seven days a week. Our wide range of services is listed below.

You should contact your local distributor for product pricing, availability, ordering, expediting, and repairs.

#### Web Site

Use the Eaton web site to find product information. You can also find information on local distributors or Eaton's sales offices.

#### Web Site Address

[www.eaton.com/electrical](http://www.eaton.com/electrical)

#### EatonCare Customer Support Center

Call the EatonCare Support Center if you need assistance with placing an order, stock availability or proof of shipment, expediting an existing order, emergency shipments, product price information, returns other than warranty returns, and information on local distributors or sales offices.

Voice: 877-ETN-CARE (386-2273) (8:00 a.m.–6:00 p.m. EST)

FAX: 800-752-8602

After-Hours Emergency: 800-543-7038  
(6:00 p.m.–8:00 a.m. EST)

If you are in the U.S. or Canada, and have OI or PLC questions, you can take advantage of our toll-free line for technical assistance with hardware and software product selection, system design and installation, and system debugging and diagnostics. Technical support engineers are available for calls during regular business hours.

#### Technical Resource Center

Voice: 877-ETN-CARE (386-2273) (8:00 a.m.–5:00 p.m. EST)

FAX: 828-651-0549

e-mail: [TRC@Eaton.com](mailto:TRC@Eaton.com)

#### European PanelMate Support Center

This engineering company, located in Zurich, Switzerland, provides high-level quality support and repair assistance for your PanelMate products. You will receive technical and application support.

#### For Customers in Europe, contact:

BFA Solutions, Ltd.

Voice: +41 1 806.64.44 (9:00 a.m.–5:00 p.m. CET)

e-mail: [gk@bfa.ch](mailto:gk@bfa.ch)

[www.bfa.ch](http://www.bfa.ch)

#### Repair and Upgrade Service

Additional support is also available from our well-equipped Repair and Upgrade Service department. If you have questions regarding the repair or upgrade of an OI product, contact your local distributor.

#### Repair and Upgrade Service (support for OI)

Voice:

877-ETN-CARE (877-386-2273) (8:00 a.m.–5:00 p.m. EST)

414-449-7100 (8:00 a.m.–5:00 p.m. EST)

FAX: 614-882-3414

e-mail: [TRC@eaton.com](mailto:TRC@eaton.com)

## Installation

For detailed information please refer to the User Manual (publication no. MN03902011E) at [www.eaton.com/softstarters](http://www.eaton.com/softstarters).

### Mounting

Required mounting hardware is Grade 5, 3/8-16, quantity four minimum (two upper and two lower).

### Unit Weight

Frame Size	Weight of Unit Lbs (kg)
A	24 (11)
B	24 (11)
C	33 (15)
D	38 (17)
E	86 (39)
F	102 (46)

### Power Wiring

#### WARNING

**Hazardous voltage can cause electric shock and burns. To avoid shock hazard, disconnect all power to the controller, motor or other control devices before any work is performed on this equipment. Failure to do so will result in personal injury, death or substantial property damage.**

**Do not apply a disconnect device on the output of the S611 soft starter unless a means to turn off the soft starter when disconnect switch is open is used. Opening disconnect while the soft starter is operating may cause a malfunction. Closing disconnect switch while the soft starter is operating will result in a soft starter failure and potential equipment damage and personnel hazard.**

**Note:** Short circuit protection must be applied on the line side of the soft starter.

**Do not attempt to lift the soft starter by the cover only.**

### Lug Installation

Install the lugs below the bus bar to assure anti-rotation. Refer to figure "Lug and Bolt Torque Support" on this page.

### Power Wiring Diagram

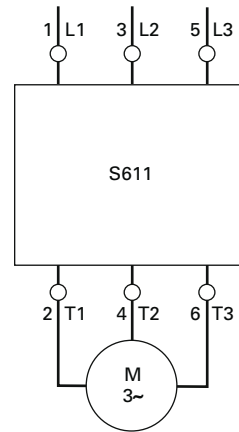

### Lug Bolt Torque Support

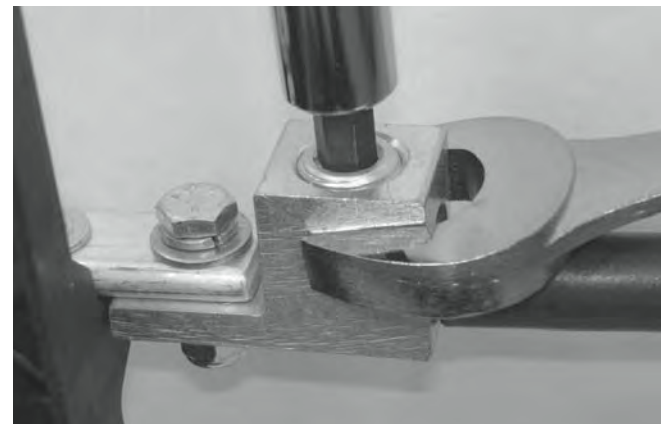

**Note:** When securing the lugs onto the bus bars of the soft starters, use a suitable tool such as another wrench to counteract the bolt torque and prevent excessive side loads being placed on the supports. Refer to figure "Lug and Bolt Torque Support" above.

Remove the tie wraps for CTs on Frames C, D, E, and F. Move each CT to the load cables during assembly as shown in the figure "CT Location" on **Page 2**. Each CT should be properly supported with tie wraps ensuring that the CT is not supported by the leads. Properly secure CT leads.

When securing the Current Transformers (CTs) onto the T1, T2, and T3 bus bars of the soft starter, correct orientation of the CT must be observed to ensure proper operation of the soft starter. Each CT is marked with a symbol "IX" adjacent to the leads. This symbol shown in the figure "CT Polarity Identification" on **Page 2** indicates the line side (or voltage source side) of the device.

# Installation

## CT Polarity Identification



## CT Location

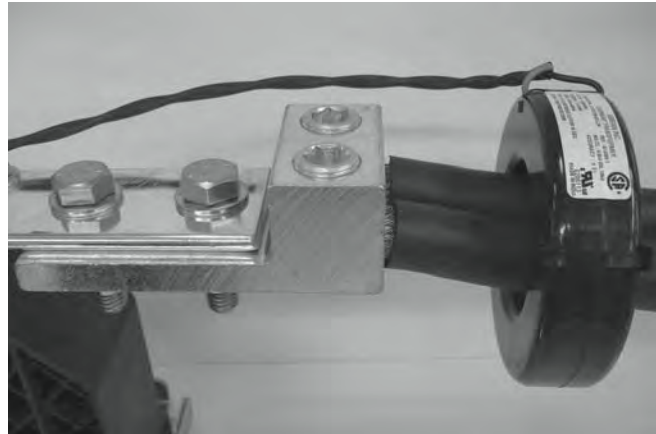

## Line and Load Power Wiring <sup>①②</sup>

Current Rating	Conductor Size <sup>③</sup>	Number of Conductors	Mechanical Lug— Ilsco Part Number	Torque lb-in	Mechanical Lug Range	Soft Starter Catalog Number	Mechanical Lug— Eaton Catalog Number
52A	6 AWG	1	TA-2/0	120	14 AWG–2/0	<b>S611A052XXX</b>	<b>S611-LUG-M01</b>
65A	4 AWG	1	TA-2/0	120	14 AWG–2/0	<b>S611A065XXX</b>	<b>S611-LUG-M01</b>
77A	3 AWG	1	TA-2/0	120	14 AWG–2/0	<b>S611A072XXX</b>	<b>S611-LUG-M01</b>
99A	1/0 AWG	1	TA-300	275	14 AWG–2/0	<b>S611B099XXX</b>	<b>S611-LUG-M02</b>
125A	2/0 AWG	1	TA-300	275	2 AWG–600 kcmil	<b>S611B125XXX</b>	<b>S611-LUG-M02</b>
156A	3/0 AWG	1	TA-600	500	2 AWG–600 kcmil	<b>S611C156XXX</b>	<b>S611-LUG-M03</b>
180A	4/0 AWG	1	TA-600	500	2 AWG–600 kcmil	<b>S611C180XXX</b>	<b>S611-LUG-M03</b>
242A	350 kcmil	1	TA-600	500	2 AWG–600 kcmil	<b>S611D242XXX</b>	<b>S611-LUG-M03</b>
302A	3/0 AWG	2	AU-600-2NS	500	2 AWG–600 kcmil	<b>S611E302XXX</b>	<b>S611-LUG-M04</b>
361A	4/0 AWG	2	AU-600-2NS	500	2 AWG–600 kcmil	<b>S611E361XXX</b>	<b>S611-LUG-M04</b>
414A	300 kcmil	2	AU-600-2NS	500	300–800 kcmil	<b>S611F414XXX</b>	<b>S611-LUG-M04</b>

### Notes

- ① Additional lug selection may be found in **Appendix D** of the User Manual, Publication No. MN03902011E.
- ② Each lug kit consists of three lugs. Two kits are required for both line and load connections.
- ③ Wire size based on 125% of UL 508 Table 43.2.

## Short-Circuit Rating

Suitable for use on a circuit capable of delivering not more than 100,000 rms symmetrical amperes, 600 volts maximum when protected by Class RK5 fuses or a circuit breaker having an interrupting rating not less than 65,000 rms symmetrical amperes, 480 volts maximum.

### Mounting Hole Dimensions

Approximate Dimensions in mm [Inches]

#### Frames A through D

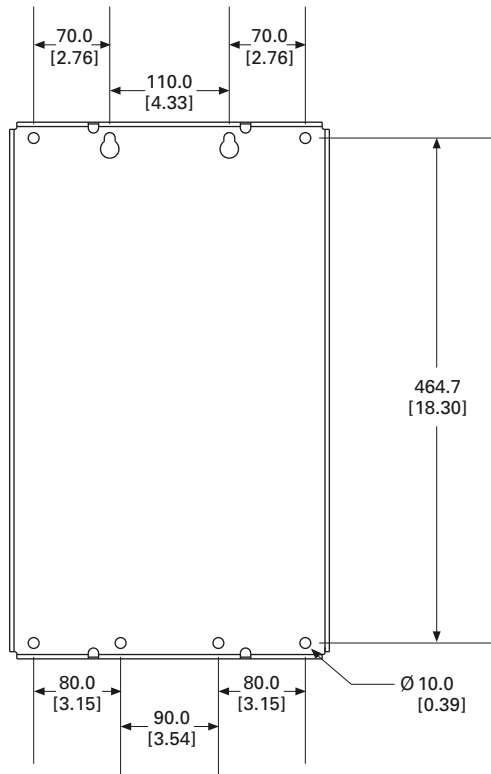

#### Frames E and F

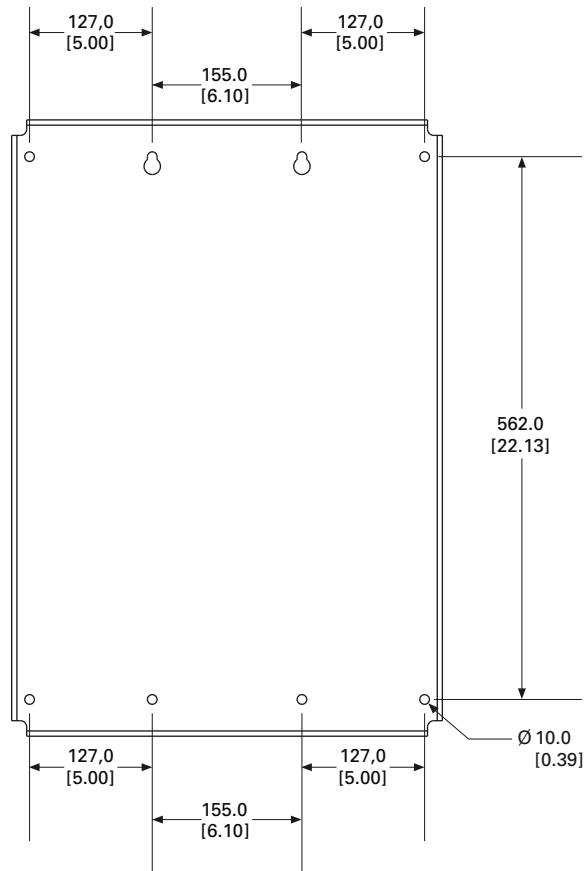

# Installation

## Typical Control Wiring Diagrams

For a single conductor, a minimum wire of 14 AWG (2.5 mm<sup>2</sup>) should be used between the control power transformer and the supply terminals.

### Basic Connection Diagram for 120 Vac Three-Wire Pushbutton

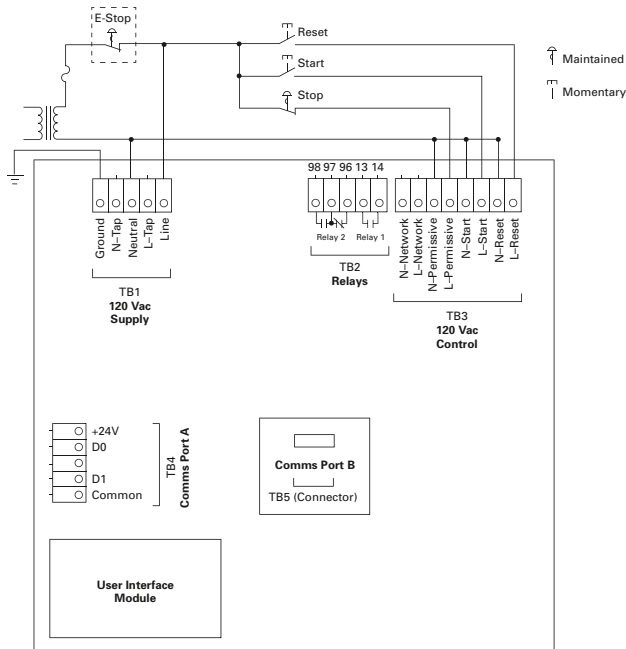

### Basic Connection Diagram for 120 Vac Two-Wire Pushbutton

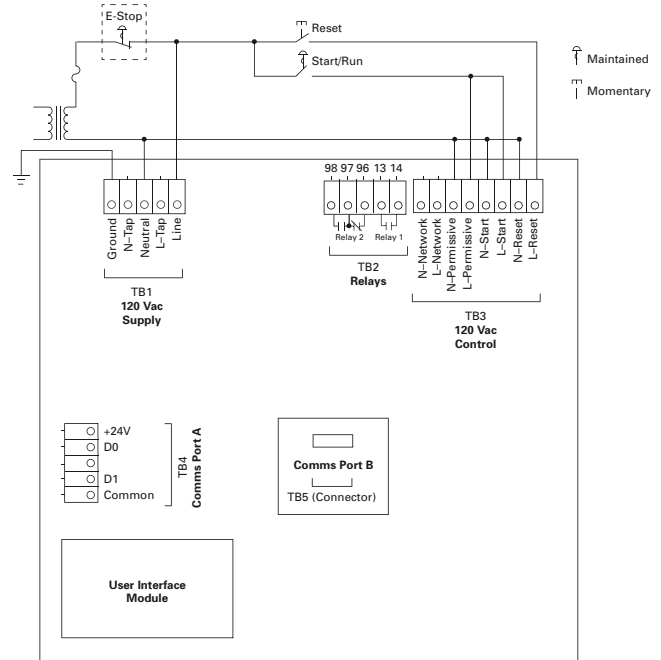

### Basic Connection Diagram for 120 Vac Network Control

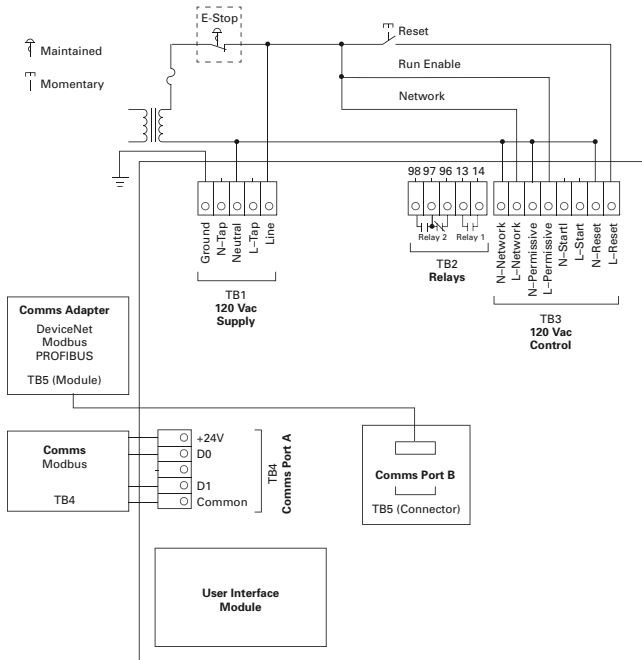

### Terminal Block Wiring Capacity

Wire Size	Number of Conductors	Torque Requirements
22–16 AWG (0.33–2.5 mm <sup>2</sup> )	2	3.5 lb-in (0.4 Nm)
14–12 AWG (4.0 mm <sup>2</sup> )	1	3.5 lb-in (0.4 Nm)



## User Interface

### User Interface Module (UI)

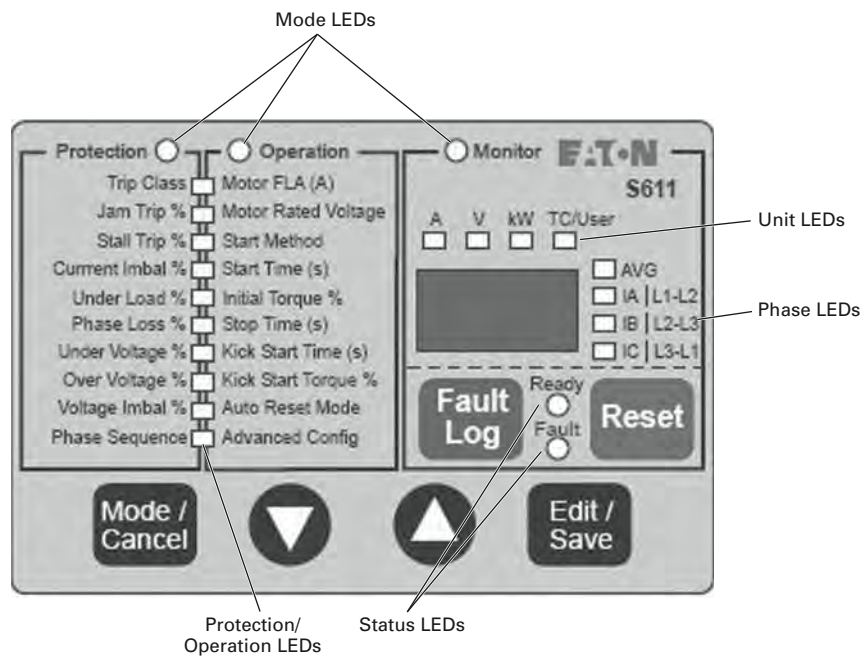

- Mode/Cancel
  - Navigate the Protection, Operation, and Monitor modes
  - Exits parameter editing mode without saving value
- Up/Down Arrow
  - Navigate Protection/Operation LED list
  - Navigates through display parameter list in Monitor mode
- Edit/Save
  - Selects/Saves parameter values in Protection/Operation modes
  - Selects Advanced Config. Menu parameters
  - Selects/Saves parameter values in Advanced Config. Parameters
  - No function in Monitor mode
- Fault Log
  - View 10 most recent fault codes
- Reset
  - Trip reset button if no active faults are present

## Setup and Starting—Initial Configuration

1. The S611 Operation and Protection parameters may be edited when 120 Vac control power is applied to 120 Vac supply (TB1). Mains power is not required to edit and save Operation and/or Protection parameters.
2. If any 120 Vac power source other than the normal system control power source is used to power the control circuit to edit parameters, connections must be made in compliance with all local, state, and national electrical codes.
3. To setup the S611 Operating parameters (Operation mode), perform the following steps:
  - a. Enter motor FLA.
  - b. Enter motor rated voltage.
  - c. Select start method if required (default = voltage ramp, or pump start).
  - d. Enter Start time from table on **Page 7** (default = 20 seconds).
  - e. Enter initial torque from table on **Page 7** (default = 45%).
- f. Enter Stop time, Kick Start time, and Kick Start torque if desired (default = 0).
4. Application Notes
 

Adjust *Initial Torque* for smooth start, motor rotation should begin within 2 seconds.

If Stall Faults occur at the end of the ramp time, increase *Initial Torque*, *Kick Start Torque and Time* and/or *Soft Start Time* to achieve bypass before the Soft Start time elapses. Verify that the motor is not overloaded.

After suitable performance has been achieved with either method, determine the starting time to bypass and set *Soft Start Time* at 1.25 times this time. For example, if it takes 10 seconds to accelerate the motor and go into bypass, set the *Soft Start Time* for 12.5 seconds.
5. In the Protection Mode, set the Protection parameters to the desired values. Refer to table on **Page 7**.
6. For optional advanced configuration parameters refer to the user manual.

### Operating Parameters

Operating Parameter	Units	Min	Max	Default	Notes
Motor FLA	Amps				Motor FLA parameter must be set to motor nameplate FLA to achieve proper overload protection
Frame Size A-52		26	52	26	
Frame Size A-65		32.5	65	32.5	
Frame Size A-77		38.5	77	38.5	
Frame Size B-99		48	99	48	
Frame Size B-125		62.5	125	62.5	
Frame Size C-156		78	156	78	
Frame Size C-180		90	180	90	
Frame Size D-242		120	242	120	
Frame Size E-302		151	302	151	
Frame Size E-361		180.5	361	180.5	
Frame Size F-414		207	414	207	
Motor rated voltage	Volts	200	600	480	—
Start method	—	0	2	0	<b>0</b> = Voltage ramp <b>1</b> = Current limit <b>2</b> = Pump start (option)
Start time ①	Seconds	0.5	180	20	—
Initial torque	%	0	100	45	—
Stop time	Seconds	0	60	0	—
Kick start time	Seconds	0	2	0	—
Kick start torque	%	0	100	0	—
Auto reset mode	—	0	1	0	<b>0</b> = Manual <b>1</b> = Auto
Advanced config	—	—	—	—	Refer to User Manual, Publication No. MN03902011E

#### Notes

- ① For the device with pump option, the default value is 2 for pump start.

**Protection Parameters**

Protection Parameter	Units	Min	Max	Default
Trip class	—	Off, 5	30	20
Jam trip	%	Off, 150	400	300
Start stall trip	%	Off, 150	400	200
Current imbalance	%	Off, 1	100	20
Under load	%	Off, 1	50	6
Phase loss	%	Off, 1	100	40
Under voltage	%	Off, 1	99	90
Over voltage	%	Off, 101	120	110
Voltage imbalance	%	Off, 1	20	6
Phase sequence	—	Off, ABC	ACB	ABC

**Note:** Editing the Trip Class parameter to “OFF” will disable overload protection.

**Torque Settings and Corresponding Current Values**

Torque Setting	Current as % Locked Rotor	Initial Motor Torque
85%	92%	Maximum
71%	84%	—
56%	75%	—
45%	67%	Default value
36%	60%	—
33%	57%	Wye-delta equivalent
27%	52%	—
19%	44%	Minimum for current limit
14%	37%	—
9%	30%	—
1%	10%	Minimum

**Start Parameter Values for Various Applications**

Application	t-Start	t-Stop	u-Start	Breakaway Torque	Remarks
Crusher, empty at start	20s	—	56%	75%	Possible high inertia
Conveyor, horizontal, loaded	25s	30s	76%	150%	—
Conveyor, horizontal, unloaded	25s	30s	48%	50%	—
Chiller	5s	—	37%	25%	—
Piston compressor, unloaded	10s	—	64%	100%	—
Circular saw	20s	—	48%	50%	Possible high inertia
Ball mill	20s	—	48%	50%	Eccentric load
Mixer, liquids	10s	—	37%	40%	—
Mixer, dry materials	15s	—	56%	75%	—
Pump, piston	25s	30s	82%	175%	Possible high starting torque
Pump, centrifugal	10s	30s	37%	25%	—
Escalator	10s	—	48%	50%	—
Rotary compressor, unloaded	20s	—	42%	35%	—
Agitator	15s	—	42%	35%	—
Feed screw	20s	—	82%	175%	Possible high starting torque
Press, flywheel	25s	—	76%	150%	Possible high starting torque
Drier, rotating	20s	—	64%	100%	—
Blower, axial fan, flaps open	30s	—	37%	25%	—
Blower, centrifugal fan, valve open	30s	—	35%	20%	—

## Troubleshooting

### S611 Fault Codes

Code	Fault	Condition	Solution
3	Watchdog	<ul style="list-style-type: none"> <li>Firmware fault</li> </ul>	—
5	Internal Memory	<ul style="list-style-type: none"> <li>Internal FRam memory error</li> </ul>	<ul style="list-style-type: none"> <li>Component failure on printed circuit board</li> <li>Contact EatonCare for service</li> </ul>
6	User Interface Communications Failure	<ul style="list-style-type: none"> <li>Communications to UI have been interrupted</li> <li>Possible hardware failure</li> </ul>	<ul style="list-style-type: none"> <li>Firmware is not communicating internally</li> <li>Cycle 120 Vac control voltage power to attempt to clear problem</li> </ul>
7	Internal Program Memory	<ul style="list-style-type: none"> <li>Corrupted firmware or memory</li> <li>Flash CRC</li> </ul>	<ul style="list-style-type: none"> <li>Cycle 120 Vac control power to the S611</li> <li>Contact EatonCare for service</li> </ul>
8	Voltage Zero Cross Lost	<ul style="list-style-type: none"> <li>Mains voltage lost</li> <li>Phase L1 or L3 lost</li> <li>Load disconnected</li> </ul>	<ul style="list-style-type: none"> <li>Restore mains or lost phases</li> <li>Verify that the load is connected and any disconnect devices are properly engaged</li> <li>Contact EatonCare for service</li> </ul>
9	Communications Loss Port A	<ul style="list-style-type: none"> <li>Communications to a remote network controller was lost during run cycle</li> <li>Device disconnected</li> <li>Connection lost</li> </ul>	<ul style="list-style-type: none"> <li>Reattach network controller, verify that the unit is recognized by the system controller</li> </ul>
10	Communications Loss Port B	<ul style="list-style-type: none"> <li>Communications to a remote network controller was lost during run cycle</li> <li>Device disconnected</li> <li>Connection lost</li> </ul>	<ul style="list-style-type: none"> <li>Reattach network controller, verify that the unit is recognized by the system controller</li> <li>Comms Port B adapter module failed or disconnected</li> </ul>
15	Power Pole Over Temperature	<ul style="list-style-type: none"> <li>SCR temperature is above limits</li> <li>Operating environment above specified maximum temperature</li> <li>Ventilation holes blocked</li> <li>Fans are not operational</li> <li>Starts/hour exceed specifications</li> <li>Sensor failure on power pole</li> <li>Bypass contactor(s) failed to close</li> </ul>	<ul style="list-style-type: none"> <li>Ventilate to specified maximum temperatures</li> <li>Clear obstructions</li> <li>Verify fans are operational</li> <li>Verify system is not exceeding the specified maximum starts per hour</li> <li>Verify bypass contacts are closing at the end of ramp time</li> <li>Reduce excessive cabinet temperature</li> </ul>
16	Bypass Failure	<ul style="list-style-type: none"> <li>Internal bypass contactor(s) not closed and/or electrically sealed after ramp time</li> <li>Contactor(s) opened in bypass</li> </ul>	<ul style="list-style-type: none"> <li>Verify all bypass contactor(s) close (audible noise)</li> <li>Verify all bypass contactor(s) not opening during run cycle due to excessive vibration and/or shock Reduce levels of vibration and/or shock</li> <li>Verify control power and wire size meet specifications</li> <li>Verify that the control power supply meets the 120 Vac voltage and current requirements of the <b>IT</b> soft starter</li> </ul>
17	SCR Not Firing	<ul style="list-style-type: none"> <li>SCR is not conducting when gated Incoming phase lost</li> <li>Special application—undersized or high impedance motor</li> <li>Load disconnected</li> </ul>	<ul style="list-style-type: none"> <li>SCR failure</li> <li>Re-apply lost phase</li> <li>Review S611 application</li> <li>Circuitry damaged by megger testing</li> <li>Contact EatonCare for service</li> </ul>

**S611 Fault Codes, continued**

<b>Code</b>	<b>Fault</b>	<b>Condition</b>	<b>Solution</b>
18	Shorted SCR ①	<ul style="list-style-type: none"> <li>SCR is shorted</li> <li>Internal bypass contactor welded shut</li> <li>No load on the SCRs when START command is issued</li> </ul>	<ul style="list-style-type: none"> <li>Test resistance of each phase</li> <li>Contact EatonCare for service</li> </ul>
19	Instantaneous Overcurrent	<ul style="list-style-type: none"> <li>Excessive starting current</li> <li>Excessive load</li> </ul>	<ul style="list-style-type: none"> <li>Reduce starting load</li> <li>Increase soft starter capacity (be sure model ratings can handle current demands)</li> </ul>
20	Overload	<ul style="list-style-type: none"> <li>Motor overloaded for an extended period of time</li> <li>Thermal memory is over 100%</li> </ul>	<ul style="list-style-type: none"> <li>Reduce the motor's load</li> <li>Verify the <i>Overld Trip FLA</i> and/or <i>Overld Trip Class</i> for proper adjustment</li> <li><b>Note:</b> Exceeding nameplate ratings will shorten equipment life</li> <li>Fault during motor start: Verify system is not exceeding the specified maximum starts per hour</li> <li>Increase the initial torque and/or reduce ramp time to bring the motor up to speed faster</li> <li>Increase Trip Class setting (5–30 maximum) and/or reduce ramp time setting</li> </ul>
21	Mains AC Voltage Loss	<ul style="list-style-type: none"> <li>Fuses or breaker open</li> <li>Disconnect open</li> </ul>	<ul style="list-style-type: none"> <li>Replace fuses, close disconnect, or reset breaker</li> </ul>
22	Under Voltage	<ul style="list-style-type: none"> <li>Incoming AC line voltage below trip threshold</li> <li>Incorrect mains supply voltage</li> </ul>	<ul style="list-style-type: none"> <li>Connect to correct supply voltage</li> <li>Verify that mains voltage is within acceptable values</li> <li>Verify <i>Motor Rated Voltage</i> in the <i>Operation</i> mode is set to the correct value</li> </ul>
23	Over Voltage	<ul style="list-style-type: none"> <li>Incoming AC line voltage above trip threshold</li> <li>Incorrect mains supply voltage</li> </ul>	<ul style="list-style-type: none"> <li>Connect to correct supply voltage</li> <li>Verify <i>Motor Rated Voltage</i> in the <i>Operation</i> mode is set to correct value</li> </ul>
24	Phase Reversal	<ul style="list-style-type: none"> <li>Incoming line phase rotation sequence opposite of device setting</li> <li>Single-phase missing and/or open fuse or breaker</li> </ul>	<ul style="list-style-type: none"> <li>Set <i>Phase Sequence</i> to match incoming sequence OR</li> <li>Exchange two incoming mains phases</li> <li>Verify that all circuit breakers are closed or fuses are serviceable</li> </ul>
25	Start Stall	<ul style="list-style-type: none"> <li>Motor not at rated RPM at end of start ramp time and/or current is in excess of trip threshold</li> <li>Bypass contactors not closed at the end of the start time (start current low/ramp time short)</li> </ul>	<ul style="list-style-type: none"> <li>Lengthen <i>Soft Start Time</i> and/or increase <i>Initial Torque</i> in the <i>Operations</i> mode</li> <li>Increase trip threshold</li> <li>Loads that are heavily loaded (high inertia) during a start such as fans will often need an initial torque setting much greater than the factory default</li> <li>Set <i>Kick Start</i> parameters</li> </ul>
27	SCR Overcurrent	<ul style="list-style-type: none"> <li>Excessive SCR current during the start ramp</li> <li>Only active when Stall Fault is disabled</li> </ul>	<ul style="list-style-type: none"> <li>Increase <i>Soft Start Time</i> and/or <i>Initial Torque</i> parameters in <i>Operation</i> mode</li> <li>Reduce starting load</li> <li>Verify S611 is properly rated for current</li> </ul>
28	Under Load	<ul style="list-style-type: none"> <li>Loss of motor load</li> <li>Trip threshold set too high</li> <li>Excessive current fluctuation during operation</li> </ul>	<ul style="list-style-type: none"> <li>Inspect for failed motor coupling or pump cavitation</li> <li>Reduce trip threshold</li> <li>Increase trip delay time to ride through transient load changes</li> </ul>

**Note**

① Shorted SCRs are the most common mode of SCR failure. With power completely removed from the unit, measure the resistance of each pole, line to load. If the resistance is near zero (less than 5 ohms), it is most likely that the SCR is shorted. Resistance of a serviceable SCR is approximately 10k ohms. Resistance typically moves to a lower value as the SCR ages. This feature may be disabled (not recommended).

# Troubleshooting

## S611 Fault Codes, continued

Code	Fault	Condition	Solution
29	Current Unbalance	<ul style="list-style-type: none"> <li>The current imbalance of the incoming phases exceeds the trip threshold</li> </ul>	<ul style="list-style-type: none"> <li>Correct imbalance problem with mains</li> <li>Increase the <i>Current Imbalance</i> parameters</li> <li>Disable the fault if the other issues cannot be resolved</li> </ul>
30	Current Phase Loss	<ul style="list-style-type: none"> <li>Incoming phase disconnected</li> <li>Open fuse or breaker</li> <li>Phase imbalance exceeds specifications or trip parameter</li> <li>Severe voltage phase imbalance</li> </ul>	<ul style="list-style-type: none"> <li>Repair broken connection</li> <li>Replace fuse</li> <li>Inspect system for phase imbalance conditions</li> </ul>
31	Voltage Phase Imbalance	<ul style="list-style-type: none"> <li>The voltage imbalance of the incoming phases exceeds the trip threshold</li> </ul>	<ul style="list-style-type: none"> <li>Correct imbalance problem with mains</li> <li>Increase the <i>Voltage Fault Imbalance</i> parameters</li> <li>Disable the fault if the other issues cannot be resolved</li> </ul>
33	Jam	<ul style="list-style-type: none"> <li>Soft starter in bypass: Motor below rated RPM and/or current exceeds 3 x motor FLA</li> </ul>	<ul style="list-style-type: none"> <li>Remove obstruction</li> <li>Verify proper FLA setting in Operation mode</li> <li>Jam fault can be disabled if trips occur during normal operation (Overcurrent fault will provide protection at a higher current threshold of 4 x catalog FLA)</li> </ul>
34	Contactor Overcurrent	<ul style="list-style-type: none"> <li>Only active in bypass if the jam fault is disabled</li> <li>Current exceeds the fault threshold of 4 x catalog FLA</li> </ul>	<ul style="list-style-type: none"> <li>Remove obstruction in motor drive train</li> <li>Verify S611 is properly sized for the application</li> </ul>
35	Missing Temp Sensor	<ul style="list-style-type: none"> <li>Temperature sensor failure</li> <li>Internal connection failure</li> </ul>	<ul style="list-style-type: none"> <li>Internal hardware failure (sensor and/or cable)</li> <li><b>Note:</b> Disabling this feature (<i>Temp Sense</i> fault in <i>Protection</i> menu) will remove protection from excessive temperature exposure (not recommended)</li> <li>Not field repairable, contact Eaton Support</li> </ul>
*	Cannot RESET fault	<ul style="list-style-type: none"> <li>Fault condition still exists</li> <li>Soft starter has not received RESET signal</li> </ul>	<ul style="list-style-type: none"> <li>Troubleshoot fault and correct defective condition</li> <li>Attempt alternate methods of RESET</li> </ul>
NC	No communication	<ul style="list-style-type: none"> <li>Firmware not programmed, firmware corrupted</li> </ul>	<ul style="list-style-type: none"> <li>Contact EatonCare for service</li> </ul>

**Note:** All mains and control power connections must be completed and voltage applied prior to a START command. Failure to make all connections will result in one or more faults.

All isolation and/or reversing contactors must be staged prior to any START commands. Manipulating contactors after the START command will result in one or more faults.



Eaton is dedicated to ensuring that reliable, efficient and safe power is available when it's needed most. With unparalleled knowledge of electrical power management across industries, experts at Eaton deliver customized, integrated solutions to solve our customers' most critical challenges.

Our focus is on delivering the right solution for the application. But, decision makers demand more than just innovative products. They turn to Eaton for an unwavering commitment to personal support that makes customer success a top priority. For more information, **visit [www.eaton.com/electrical](http://www.eaton.com/electrical)**.

**Eaton Corporation**  
Electrical Sector  
1111 Superior Ave.  
Cleveland, OH 44114  
United States  
[Eaton.com](http://Eaton.com)

© 2012 Eaton Corporation  
All Rights Reserved  
Printed in USA  
Publication No. MN03901003E / Z11687  
January 2012

Eaton is a registered trademark  
of Eaton Corporation.

All other trademarks are property  
of their respective owners.