

Residential Packaged Fire Pump System

# HDR-50

Heavy Duty Residential Package  
Design Condition: 50GPM @ 65PSI

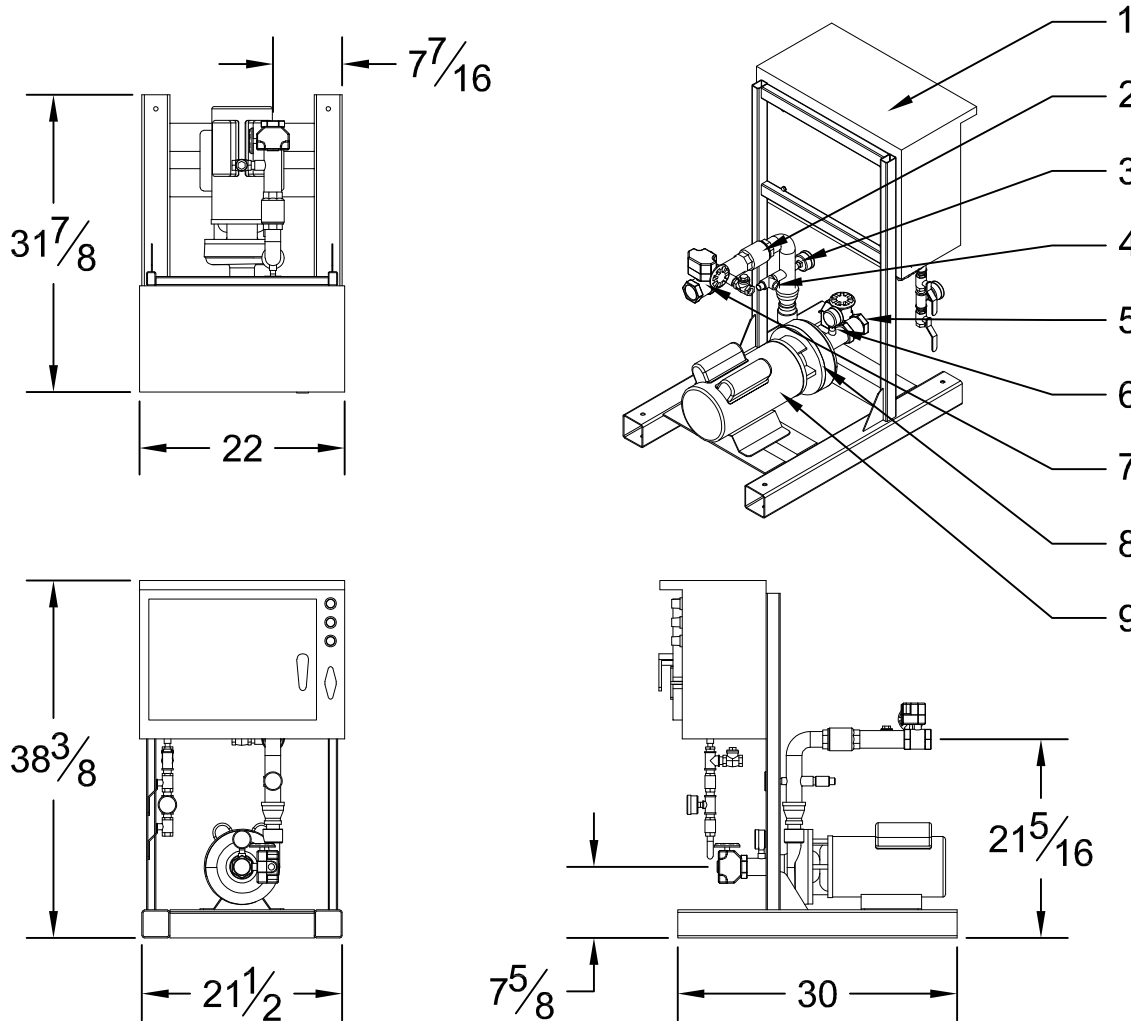

### System Specifications:

- Motor
- 5 Horsepower Electric
  - 230 Volt
  - 21.5 Amp
  - Single Phase
  - 3450 RPM

- Pump
- End Suction Centrifugal Pump
  - 1 1/2" Suction (NPT)
  - 1 1/2" Discharge (NPT)
  - 175 PSI max working pressure

- System Components
- 1- Residential Fire Pump Controller
  - 2- Check Valve
  - 3- Discharge Pressure Gauge
  - 4- Case Relief Valve
  - 5- Suction Monitored Butterfly Valve
  - 6- Suction Pressure Gauge
  - 7- Discharge Monitored Butterfly Valve
  - 8- End Suction Pump
  - 9- Electric Motor
  - Not Shown- Copper Sensing Line (per NFPA20)

### Performance

Performance values based on multiple pump tests. Not for certification purposes.

GPM	0	40	45	50	55	60	65	70	75
PSI	74	70	69	67	66	64	60	57	52

Please Note: This fire pump system uses an unlisted pump & a residential controller.

Please submit to your AHJ for approval prior to ordering.